

To _____

No. A226-040403B-01

Date 3rd Apr. '04

Type No.
GRAB4

Data Sheet

GPS Rx SAW Filter	
Application	: Rx Filter for GPS
Center Frequency	: 1575.42MHz
Size	: 2.0x1.4mm, 5pin-layout
Impedance	: 50-100ohms unbalance-balance
Part No.	: EFCH1575TCA1

Issued *Y. Watanabe*

Check *K. Nishimura*

CIRCUIT COMPONENTS BUSINESS UNIT

MATSUSHITA ELECTRONIC COMPONENTS CO.,LTD

KADOMA, OSAKA, JAPAN

GPS RF SAW Filter, 1575.42MHz
Design NO. dubw027
== Preliminary Specification ==

Parameter		Frequency (MHz)	Your requirements			Our puropusal			Unit
			Min.	Typ.	Max.	Min.	Typ.	Max.	
Center Frequency (fo)				1575			1575.4		
Insertion Loss		1575.42 MHz			1.8		1.1	1.5	dB
Pass band ripple		1574.42 to 1576.42MHz			0.7		0.1	0.3	dBpp
Attenuation	Att1	<1475MHz	30			35	42		dB
	Att2	1475 to 1525MHz	10			20	25		
	Att3	1625 to 1675MHz	10			20	27		
	Att4	1675 to 3155MHz	30			30	35		
	Att5	>3155MHz	20			30	43		
Mean Square Phase Error		1574.42 to 1576.42MHz			1		0.4	0.8	°rms
Phase Imbalance					+/-20	-20	5	20	Degree
Amplitude Imbalance					+/-2	-2	0.8	2	dB
In/Out VSWR		1574.42-1576.42		1.1	1.5		1.1	1.5	
Terminate impedance(in)		Single-ended	50			50			ohm
(out)		Differential	100			100			ohm
Operating Temperature			-30	25	85	-30	25	85	°C

a value which pulled JIG Loss:0. 2dB.

GPS Rx SAW Filter

Design No dubw027

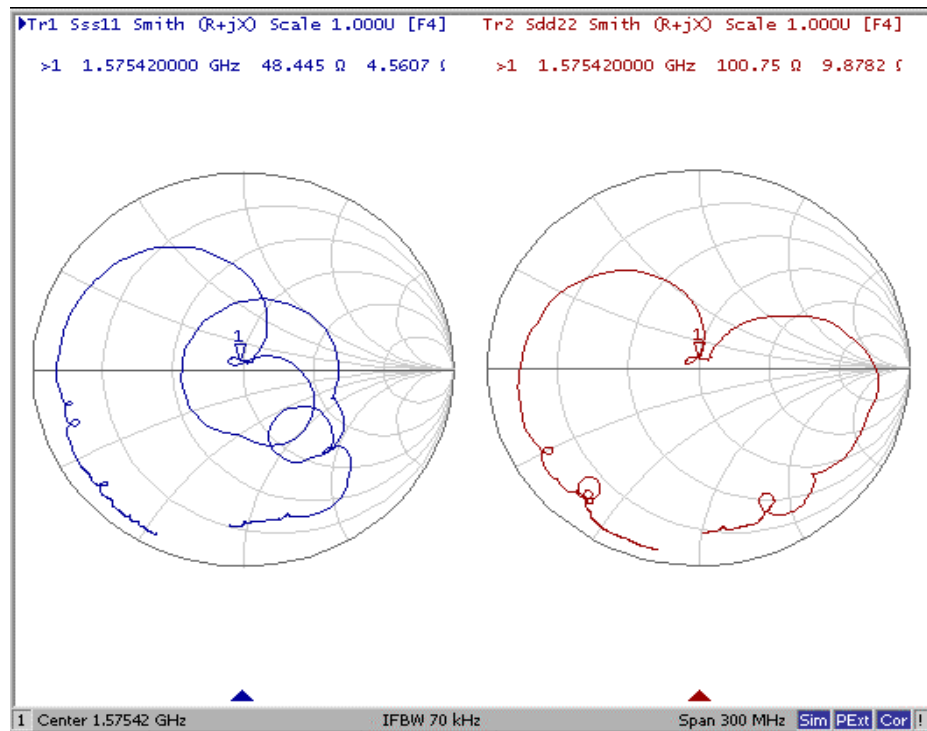
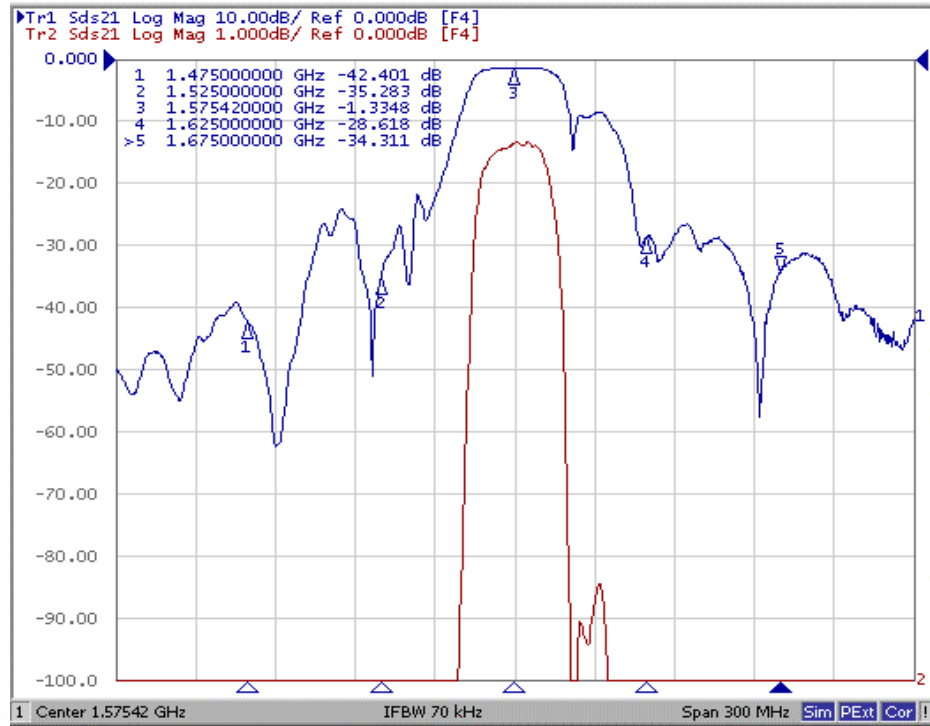

GPS Rx SAW Filter

Design No dubw027

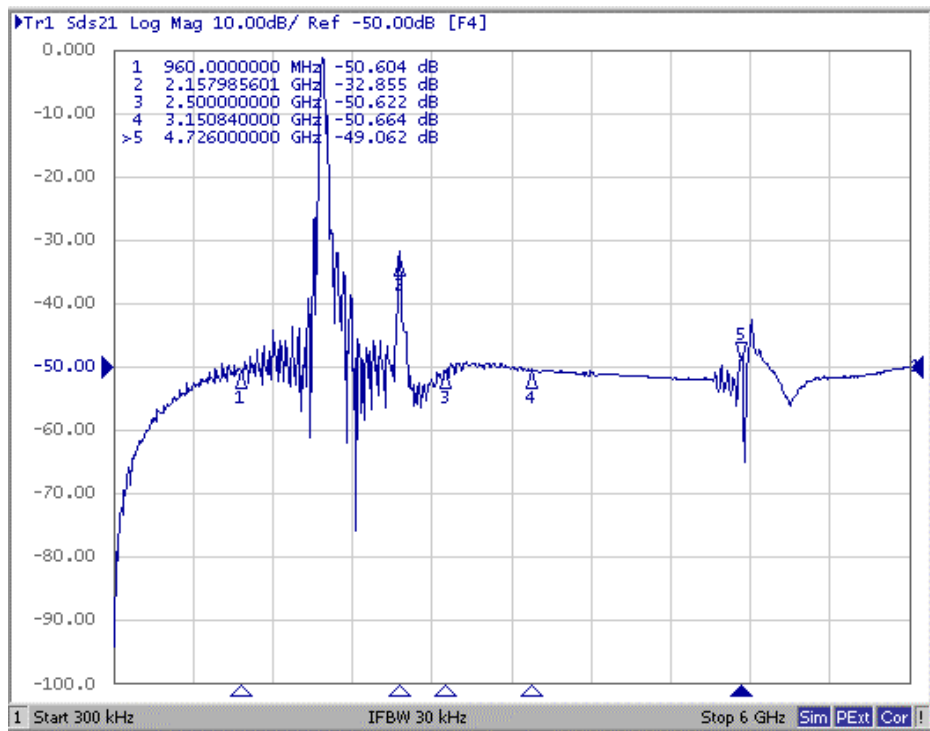

GPS Rx SAW Filter

Design No dubw027

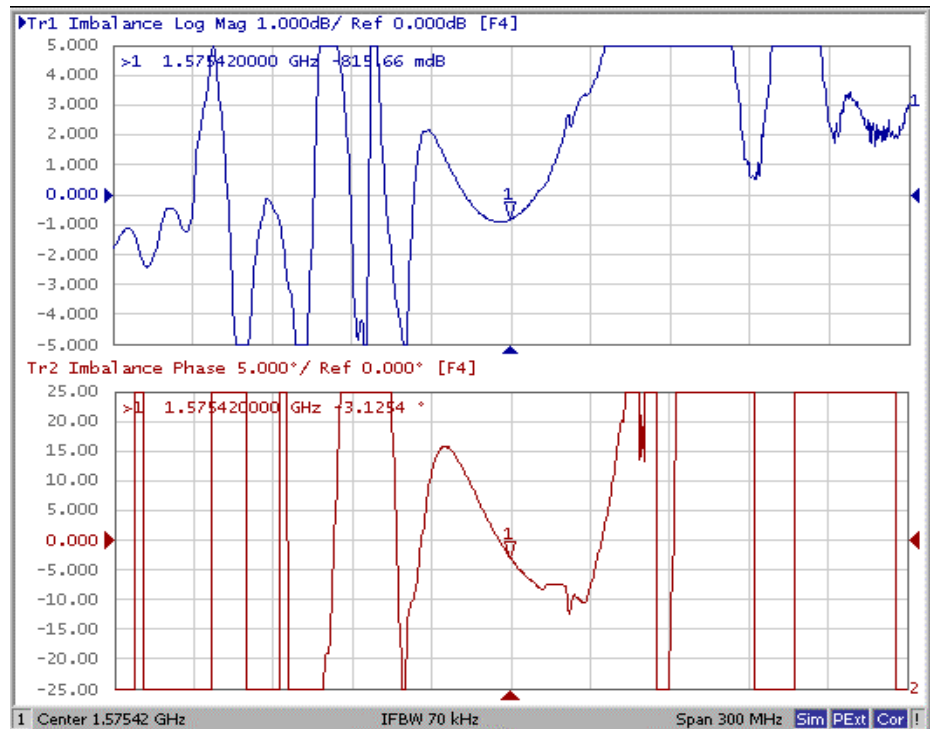
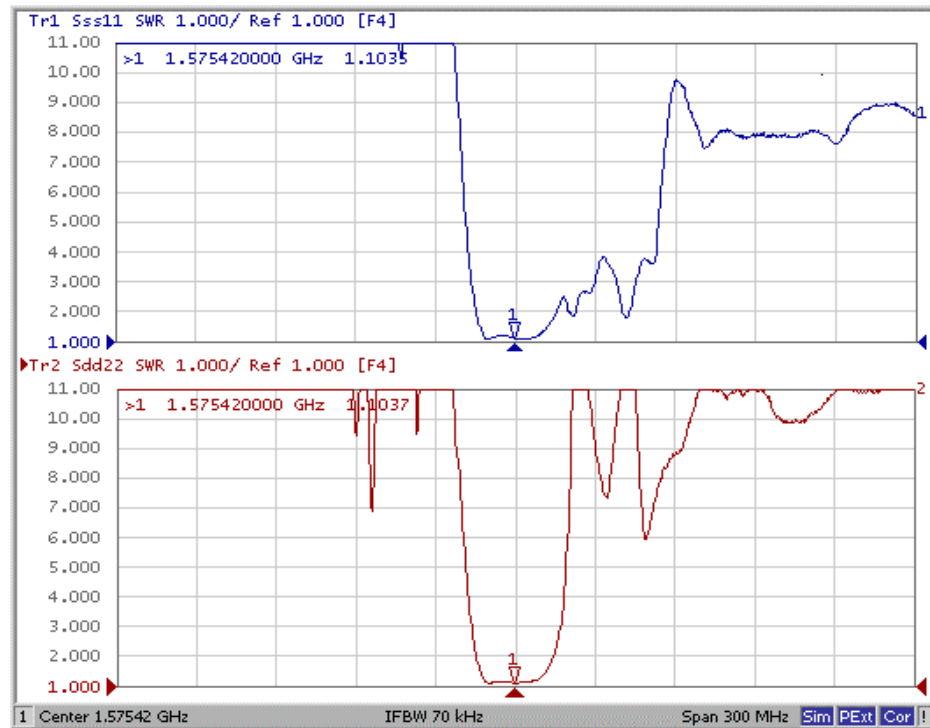

THIRD ANGLE PROJECTION

Tolerance : +/-0.05

Under Development

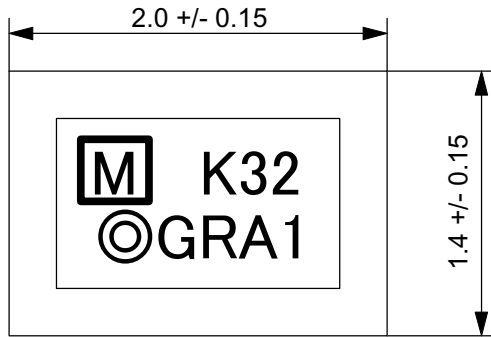

Marking
 $\frac{K\ 3\ 2}{\textcircled{3}\ \textcircled{2}}$
 $\frac{GRA1}{\textcircled{1}}$

- ①: Type Symbol
- ②: Date Code
3_YEAR
2_MONTH
- ③: Factory Copde
(Show the production place as below)
K:MACO

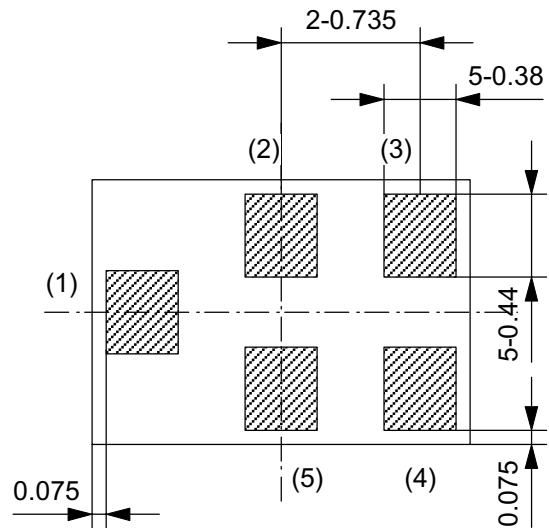
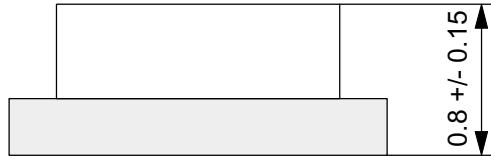

- (1) Input
- (2) GND
- (3) Output
- (4) Output
- (5) GND

Note :
 The design manufacturing process,
 and Specification of this device
 are subject to change without
 notice.

UNLESS OTHERWISE SPECIFIED		
BASIC DIMENSIONS		TOLERANCE
UP TO	INCL	
TO	INCL	
TO	INCL	
TO	INCL	
ABOVE		

--	--	--

ISSUE	REVISIONS	DATE
MATERIAL	FINISH	SCALE
DESIGN		
DRAW		
CHECK		
APPROVAL		
DRAWING NO.		

NAME	TYPE NO.
SAW Filter	

**CERAMIC BUSINESS UNIT, LCR DEVICE COMPANY
 MATSUSHITA ELECTRONIC COMPONENTS CO.,LTD.
 KADOMA, OSAKA, JAPAN**

DO NOT SCALE DRAWING

REVISIONS INDICATED BY Æ

ALL DIMENSIONS ARE IN MILLIMETERS

THIRD ANGLE PROJECTION

Mesurement Circuit

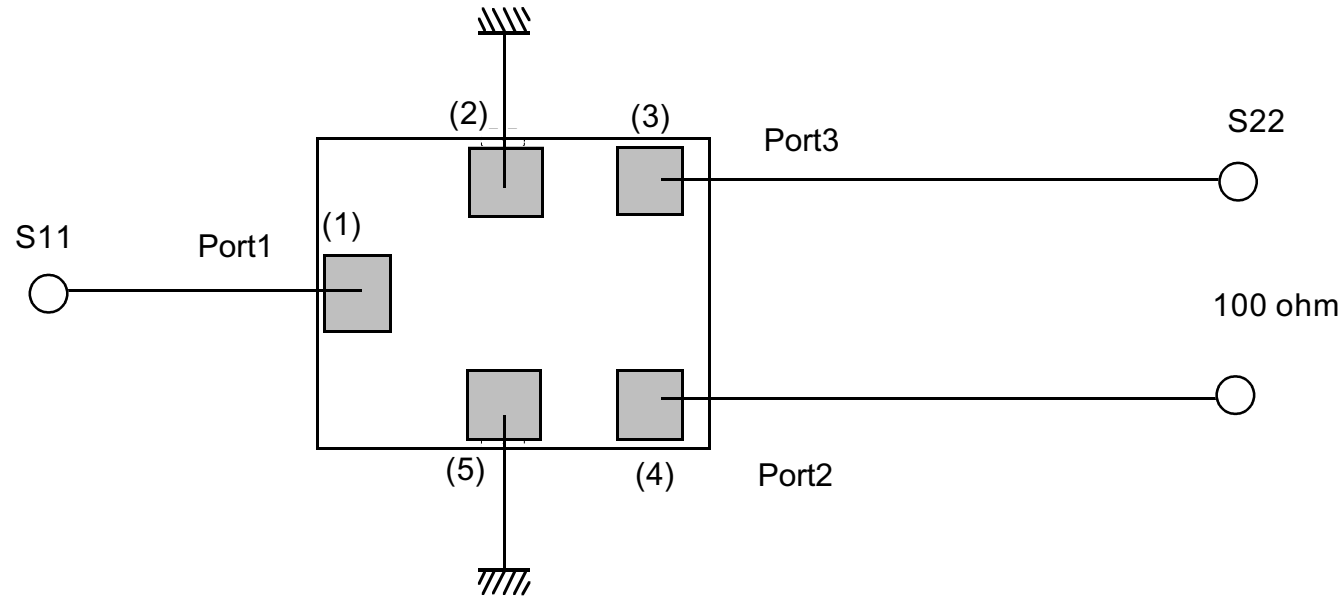

Input impedance:50 Oohm (Single ended)
 Output impedance:100 Oohm (Differential)

UNLESS OTHERWISE SPECIFIED

BASIC DIMENSIONS		TOLERANCE
UP TO	INCL	
TO	INCL	
TO	INCL	
TO	INCL	
ABOVE		

--	--	--

ISSUE	REVISIONS		DATE
	MATERIAL	FINISH	SCALE
	DESIGN		
	DRAW		
	CHECK		
	APPROVAL		
DRAWING NO.			

NAME NO.	SAW filter	TYPE
----------	-------------------	------

CERAMIC BUSINESS UNIT , LCR DEVICE COMPANY
 MATSUSHITA ELECTRONIC COMPONENTS CO.,LTD.
 KADOMA, OSAKA, JAPAN

THIRD ANGLE PROJECTION

UNLESS OTHERWISE SPECIFIED

Recommended land pattern

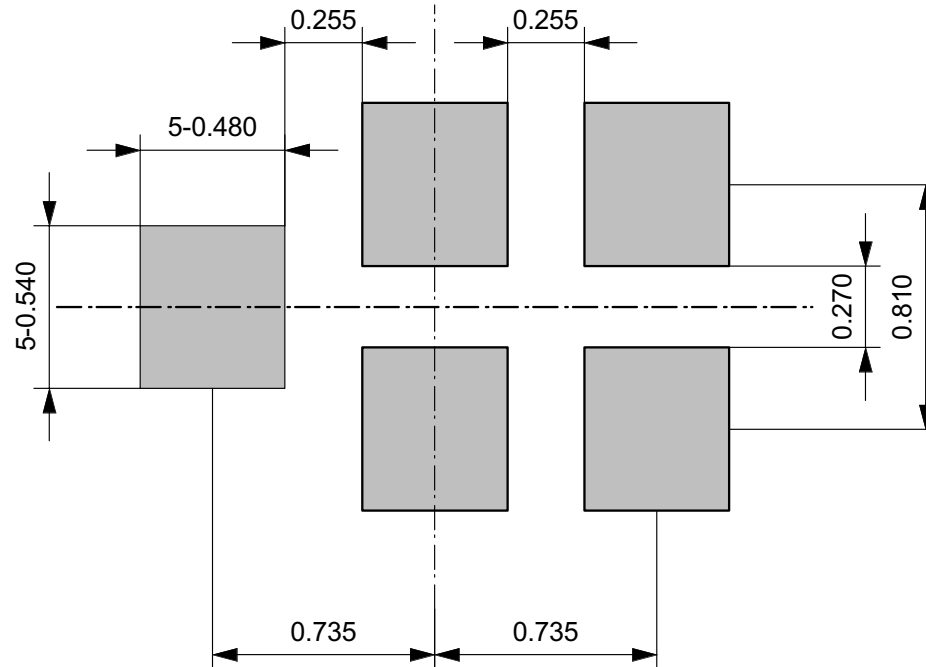

Note :
The design manufacturing process, and Specification of this device are subject to change without notice.

UNLESS OTHERWISE SPECIFIED		
BASIC DIMENSIONS		TOLERANCE
UP TO	INCL	
TO	INCL	
TO	INCL	
TO	INCL	
ABOVE		

--	--	--

ISSUE	REVISIONS	DATE
MATERIAL	FINISH	SCALE
DESIGN		
DRAW		
CHECK		
APPROVAL		
DRAWING NO.		

NAME	SAW Filter
------	------------

TYPE NO.	
----------	--

**CERAMIC BUSINESS UNIT, LCR DEVICE COMPANY
 MATSUSHITA ELECTRONIC COMPONENTS CO.,LTD.
 KADOMA, OSAKA, JAPAN**